

7 Frame Plunger Pump

Models

530
550

FEATURES

Superior Design

- Triplex plunger provides smoother liquid flow.
- Hi-Pressure Seals or V-Packings are completely lubricated and cooled by the liquid being pumped.
- Inlet and discharge valve assemblies interchange for easier maintenance.
- Lubricated Lo-Pressure Seals provide double protection against external leakage.
- Oil bath crankcase assures optimum lubrication.
- Close tolerance concentricity of the ceramic plunger maximizes seal life.

Quality Materials

- Precision design 304 stainless steel valves and seats are hardened and polished for ultimate seating and extended valve life.
- Forged brass manifold is strong and corrosion resistant.
- Special concentric, high-density, polished, solid ceramic plungers provide a true wear surface and extended seal life.
- Specially formulated, CAT PUMP exclusive, Hi-Pressure Seals or V-Packings offer unmatched performance and seal life.
- Die cast aluminum crankcase provides high strength, minimum weight and precision tolerance control.
- Chrome-moly crankshaft gives unmatched strength and surface hardness.
- Oversized crankshaft bearings with greater capacity mean longer bearing life.

Easy Maintenance

- Wet end is easily serviced without entering crankcase, requiring less time and effort.
- Valve assemblies are accessible without disturbing piping, for quick service.
- Preset packings mean no packing gland adjustment is necessary, reducing maintenance costs.

⚠ WARNING

All systems require both a primary pressure regulating device (i.e., regulator, unloader) and a secondary pressure safety relief device (i.e., pop-off valve, safety valve). Failure to install such relief devices could result in personal injury or damage to the pump or to system components. CAT PUMPS does not assume any liability or responsibility for the operation of a customer's high pressure system.

SPECIFICATIONS

U.S. Measure

Metric Measure

MODEL 530

Flow	5.0 GPM	(19 L/M)
Pressure Range.....	100 to 2500 PSI	(7 to 175 BAR)
RPM	1100 RPM	(1100 RPM)
Bore.....	0.708"	(18 mm)
Stroke.....	0.945"	(24 mm)

MODEL 550

Flow	5.0 GPM	(19 L/M)
Pressure Range.....	100 to 3000 PSI	(7 to 210 BAR)
RPM	1415 RPM	(1415 RPM)
Bore.....	0.630"	(16 mm)
Stroke.....	0.945"	(24 mm)

COMMON SPECIFICATIONS

Inlet Pressure Range.....	Flooded to 60 PSI	(Flooded to 4 BAR)
Crankcase Capacity	25 oz.	(0.75 L)
Maximum Liquid Temperature	160°F	(71°C)
<small>For temperatures above 130°F call CAT PUMPS for inlet conditions and elastomer recommendations.</small>		
Inlet Ports (2)	1/2" NPTF	(1/2" NPTF)
Discharge Ports (2).....	3/8" NPTF	(3/8" NPTF)
Shaft Diameter	0.945"	(24 mm)
Weight.....	25.5 lbs.	(11.5 kg)
Dimensions.....	13.6 x 9.61 x 6.41"	(346 x 244 x 163 mm)

ELECTRIC HORSEPOWER REQUIREMENTS

MODEL	FLOW		PRESSURE				MOTOR PULLEY SIZE	
			PSI 1800	PSI 2150	PSI 2500	PSI 3000	Using 1725 RPM Motor & Std. 10" Pulley O.D.	
	U.S. GPM	L/M	BAR 125	BAR 150	BAR 175	BAR 210	RPM	Pulley O.D.
530	5.0	19.0	6.2	7.4	8.6	N/A	1100	6.3
	4.5	17.0	5.6	6.6	7.7	N/A	990	5.6
	4.0	15.0	5.0	5.9	6.9	N/A	880	5.0
550	5.0	19.0	6.2	7.4	8.6	10.3	1415	8.0
	4.0	15.0	5.0	5.9	6.9	8.3	1130	6.4
	3.0	11.4	3.7	4.4	5.2	6.2	850	5.0

DETERMINING THE PUMP R.P.M. $\frac{\text{Rated G.P.M.}}{\text{Rated R.P.M.}}$ = $\frac{\text{"Desired" G.P.M.}}{\text{"Desired" R.P.M.}}$

DETERMINING THE REQUIRED H.P. $\frac{\text{GPM x PSI}}{1460}$ = Electric Brake H. P. Required

DETERMINING MOTOR PULLEY SIZE $\frac{\text{Motor Pulley O.D.}}{\text{Pump R.P.M.}}$ = $\frac{\text{Pump Pulley O.D.}}{\text{Motor R.P.M.}}$

See complete Drive Packages [Incls: Pulleys, Belts, Hubs, Key] Tech Bulletin 003.
Refer to pump **Service Manual** for repair procedure, additional technical information and **pump warranty**.

"Customer confidence is our greatest asset"

PARTS LIST

ITEM	PART NUMBER		DESCRIPTION	QTY
	530	550		
	MATL	MATL		
2	30067	30067	Key (M8x7.5x25)	1
5	92519	92519	Screw, HHC, Sems (M6x16)	8
	125824	125824	Screw, HHC, Sems (M6x16)	8
8	43223	43223	Cover, Bearing	2
9	815280	815280	Shim, Split, 2-Pc	1
10	12393	12393	O-Ring, Bearing Cover	2
11	43222	43222	Seal, Oil, Crankshaft	2
15	43221	43221	Bearing, Roller	2
20	48863	48863	Rod, Assy, Connecting [6/02]	3
25	43220	43220	Crankshaft, Dual End	1
31	828710	828710	Protector, Oil Cap w/Foam Gasket	1
32	43211	43211	Cap, Oil Filler	1
33	14177	14177	O-Ring, Filler Cap - 70D	1
37	92241	92241	Gauge, Oil, Bubble w/Gasket - 80D	1
38	44428	44428	Gasket, Flat, Oil Gauge - 80D	1
40	125824	125824	Screw, HHC Sems (M6x16) [06/08]	4
48	25625	25625	Plug, Drain (1/4"x19BSP)	1
49	23170	23170	O-Ring, Drain Plug - 70D	1
50	127701	127701	Cover, Rear [06/08]	1
51	14047	14047	O-Ring, Rear Cover - 70D [06/08]	1
53	127698	127698	Crankcase (M10) [06/08]	1
56	43240	43240	Pan, Oil	1
64	43237	43237	Pin, Crosshead	3
65	43229	43229	Rod, Plunger	3
69	126589	126589	Washer, Oil Seal	3
70	43228	43228	Seal, Oil, Crankcase	3
75	43328	43328	Slinger, Barrier	3
88	45697	45697	Washer, Keyhole (M18)	3
90	43232	CC	Plunger (M18x77 and M16x77)	3
96	43235	43235	Back-up-Ring, Plunger Retainer	3
97	17399	17399	O-Ring, Plunger Retainer - 80D	3
	14160	14160	O-Ring, Plunger Retainer - 70D	3
98	45891	45891	Gasket, Plunger Retainer	3
99	104360	104360	Retainer, Plunger w/Stud	3
100	45689	45689	Retainer, Seal, 2-Pc [04/06]	3
101	43239	—	Wick, Long Tab	3
106	43243	43316	Seal, LPS w/S-Spg	3
	44926	—	Seal, LPS w/SS-Spg	3
	—	106660	Seal, LPS w/S-Spg	3
120	45683	BB	Case, Seal	3
121	20285	20285	O-Ring, Seal Case - 70D	3
	11693	11693	O-Ring, Seal Case	3
125	43245	—	Seal, HPS w/S	3
	44925	—	Seal, HPS w/SS	3
126	—	43320	Adapter, Female	3
127	—	43319	V-Packing	6
	—	46287	V-Packing	6
	—	43318	Adapter, Male	3
128	—	—	Plug (1/2" NPTM)	1
139	22179	22179	Back-up-Ring, Seat	6
162	43248	43248	O-Ring, Seat - 80D	6
163	43249	43249	O-Ring, Seat - 70D	6
	44383	44383	Seat, Q.V.	6
164	43722	43722	Seat, F.V.	6
	43825	—	Valve, Q.V.	6
166	43721	43721	Valve, F.V.	6
	43824	—	Spring, Q.V.	6
167	43751	43751	Spring, F.V.	6
	43823	—	Retainer, Spring	6
168	44564	44564	O-Ring, Valve Plug - 90D	6
172	17617	17617	O-Ring, Valve Plug - 90D	6
	11691	11691	Plug, Valve	6
174	43851	43851	Head, Manifold (M10F)	1
185	45417	BB	Stud, Manifold (M10x35)	4
187	46868	46868	Nut, Flanged (M10)	4
194	126567	126567	Plug, Discharge (3/8" NPTM)	1
196	43633	43633	Protector, Shaft	1
250	43256	43256	Kit, Direct Mounting	1
255	30243	30243	Rail, Angle, Assy A-U.S. (2.09")	1
260	30645	30645	Rail, Angle, Assy B-U.S. (2.95")	1
	30611	30611	Kit, Mounting (Incls: 30645, 30206, 33000, 30067, 43256)	1
265	30660	30660	Pulley (10") [See Drive Packages, Tech Bulletin 003]	1
269	30206	30206	Hub "H", M24 (Keyway M8) [See Drive Packages, Tech Bulletin 003]	1
274	33000	33000	Kit, Oil Drain	1
283	34334	34334	Clutch Assy, Single Groove, 24mm, 12VDC	1
298	34628	34628	Clutch Assy, Dual Groove, 24mm, 12VDC	1
	34630	34630	Clutch Assy, Eight Groove Poly L, 24mm, 12VDC	1
	34959	34959	Head, Complete	1
299	812183	BB	Kit, Seal (Incls: 97, 101, 106, 121, 125 or 127)	1
300	30488	HT	Kit, Seal, HT (Incls: 97, 101, 106, 121, 127)	1
	—	—	Kit, Valve, Q.V. (Incls: 162-164, 166, 167, 168, 172)	2
310	30820	30820	Kit, Valve, F.V. (Incls: 162-164, 166, 167, 168, 172)	2
	31820	31820	Plier, Reverse	1
350	30696	30696	Tool, Seal Case Removal	1
351	43257	43257	Tool, Oil Gauge Removal	1
352	44050	44050	Plunger Pump Service DVD	1
—	6575	6575	Oil, Bottle (21 oz.) ISO 68 Multi-Viscosity Hydraulic	1-2
—	6107	6107	(Fill to specified crankcase capacity prior to start-up)	

Bold print part numbers are unique to a particular pump model. Italics are optional items.

[] Date of latest production change. R Components comply with RoHS Directive

Refer to Tech Bulletins 002, 003, 008, 024, 027, 035, 036,043, 045, 051, 053, 054, 067, 074, 077, 083 and 106 for additional information.

MATERIAL CODES (Not Part of Part Number): AL=Aluminum ABS=ABS Plastic BB=Brass BBPC=Brass/Chrome Plated CC=Ceramic CM=Chrome-Moly

CU=Copper F=Cast Iron FBR=Fiber FCM=Forged Chrome-Plastic FPM=Fluorocarbon HT=Hi-Temp NBR=Medium Nitrile (Buna-N)

POP=Polypropylene PTFE=Pure Polytetrafluoroethylene PVDF=Polyvinylidene Fluoride S=304SS SNG=Special Blend (Buna) STCP=Steel/Chrome Plated STL=Steel

STZP=Steel/Zinc Plated TNM=Special High Strength ZZCP=Zamak/Chrome Plated

EXPLODED VIEW

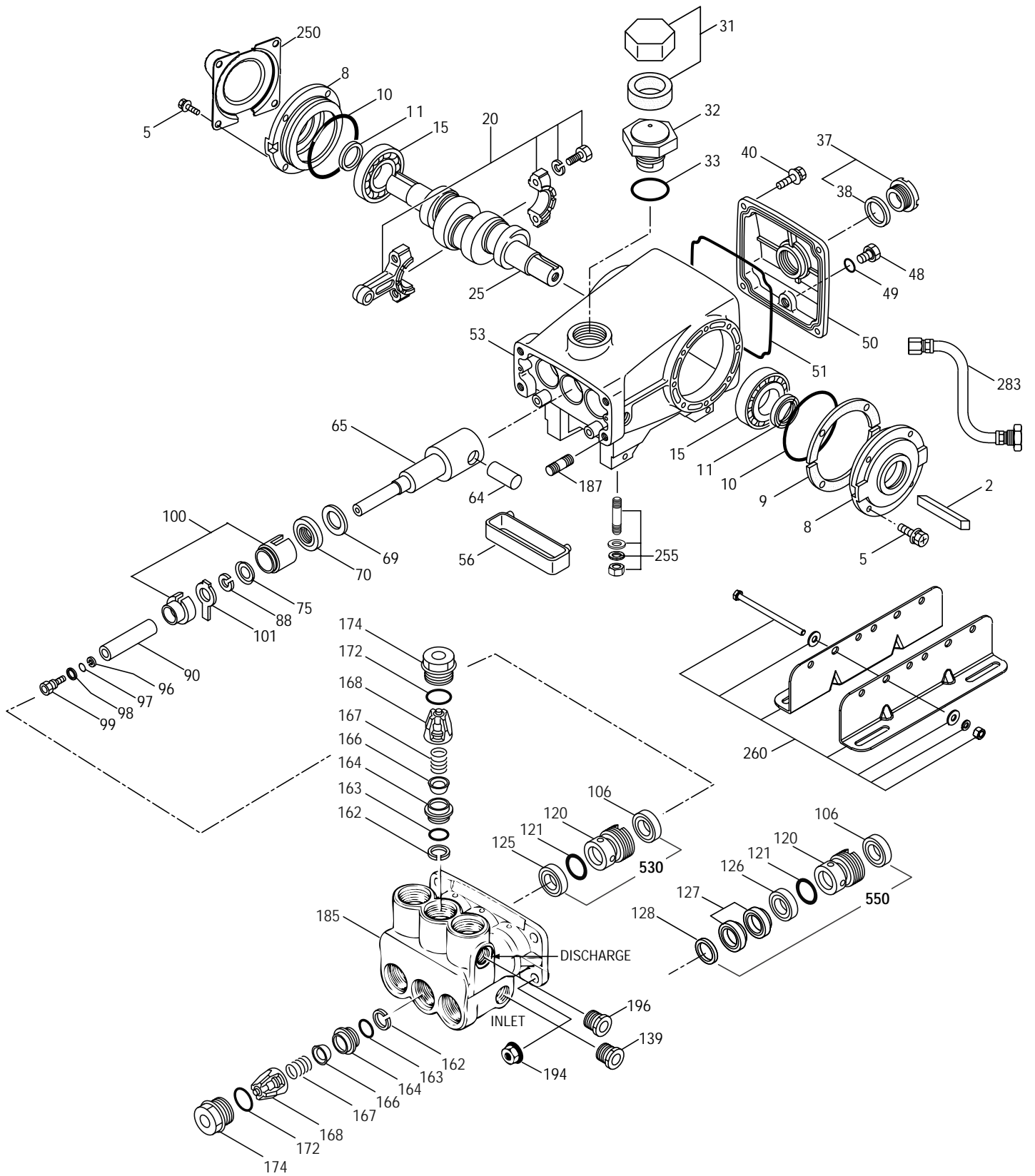

Models
530, 550
April 2008

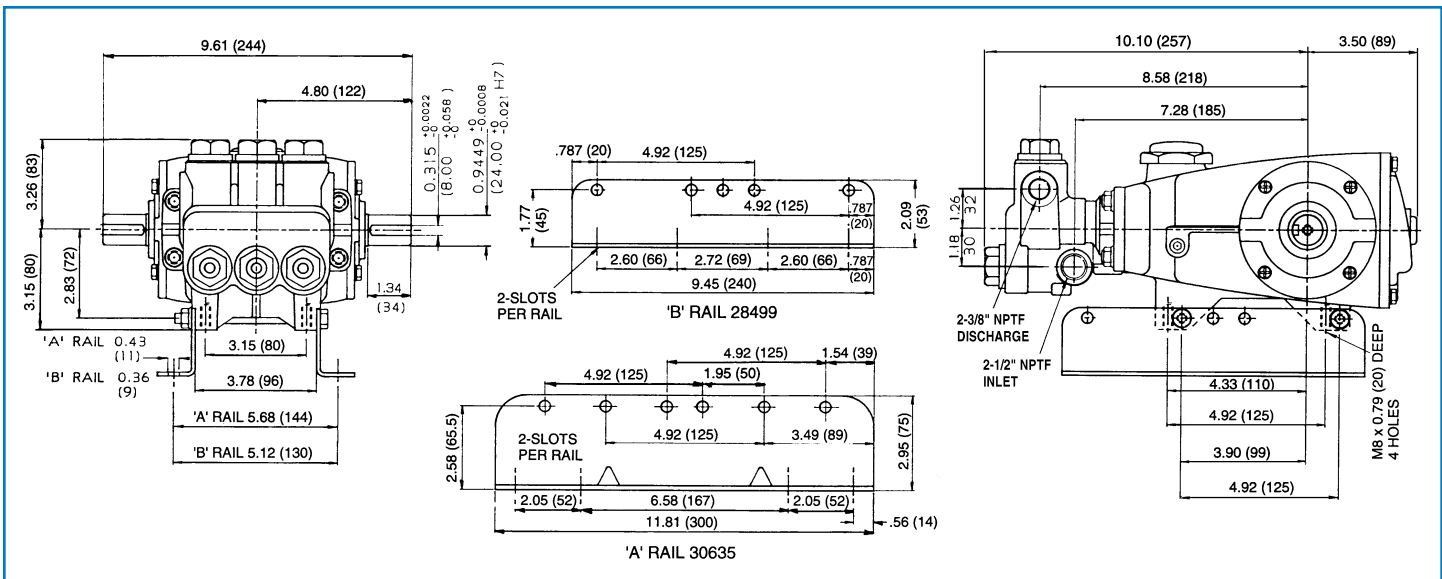

Models 530, 550

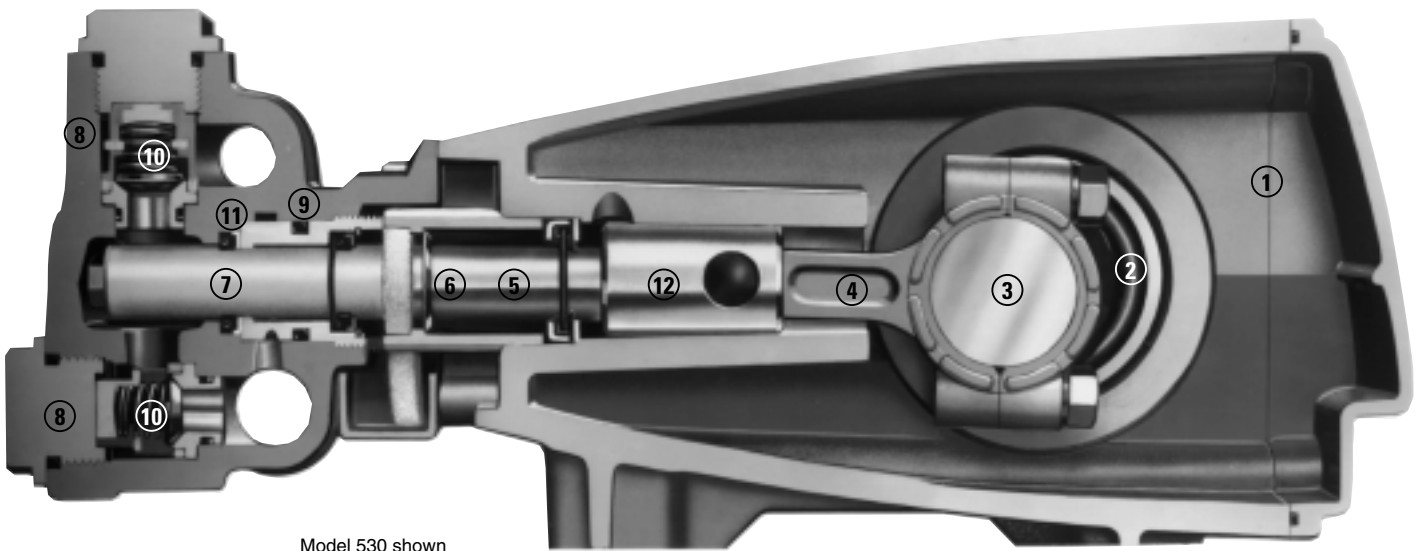

Model 530 shown

- 1 Die cast aluminum **crankcase** means high strength, lightweight, and excellent tolerance control.
- 2 Oversized crankshaft **bearings** provide extended bearing life and pump performance.
- 3 Chrome-moly **crankshaft** provides unmatched strength and surface hardness for long life.
- 4 Matched high strength **connecting rods** are for superior strength and bearing quality.
- 5 Special high strength **plunger rods** with Zamak crossheads for longevity and corrosion resistance.
- 6 The stainless steel **slinger** provides back-up protection for the crankcase seal, keeping pumped Liquids out of the crankcase.
- 7 Special concentric, high-density, polished, solid ceramic **plungers** provide a true wear surface and extended seal life.
- 8 **Manifolds** are a high tensile strength forged brass for long term, continuous duty.
- 9 100% wet **seal** design adds to service life by allowing pumped liquids to cool and lubricate on both sides.
- 10 Stainless steel **valves, seats and springs** provide corrosion-resistance, ultimate seating and extended life.
- 11 Specially formulated, CAT PUMP exclusive, **Hi-Pressure Seals/V-Packings** offer unmatched performance and seal life.
- 12 **Crossheads** are 360° supported for uncompromising alignment.

World Headquarters

CAT PUMPS

1681 - 94th Lane N.E. Minneapolis, MN 55449-4324

Phone (763) 780-5440 — FAX (763) 780-2958

e-mail: techsupport@catpumps.com

www.catpumps.com

International Inquiries

FAX (763) 785-4329

e-mail: intlsales@catpumps.com



The Pumps with Nine Lives

CAT PUMPS (U.K.) LTD.

1 Fleet Business Park, Sandy Lane, Church Crookham

FLEET, Hampshire, GU52 8BF, England

Phone Fleet 44 1252-622031 — Fax 44 1252-626655

e-mail: sales@catpumps.co.uk

N.V. CAT PUMPS INTERNATIONAL S.A.

Heiveldekens 6A, B-2550 Kontich, Belgium

Phone 32-3-450.71.50 — Fax 32-3-450.71.51

e-mail: cpi@catpumps.be www.catpumps.be

CAT PUMPS DEUTSCHLAND GmbH

Buchwiese 2, D-65510 Idstein, Germany

Phone 49 6126-9303 0 — Fax 49 6126-9303 33

e-mail: catpumps@t-online.de www.catpumps.de